

Built to LAST!

Industrial Equipment *Only Sales, Parts & Service Center from Sac. CA to Oregon!*

Environmental Cleaning Systems

WATER CLEANING SYSTEMS *Since 1987*

 **Parts Washers** 830 Cherry Street
 830 Cherry Street
 Chico, CA 95928
 PH: (800)287-8306
 (530)893-2125
 Fax: (530)893-1035
 www.industrial-equipment.biz

 **Pressure Washers**
 **Water Treatment** Lic# 795757

RE-PRESSURIZATION PUMP - MQ

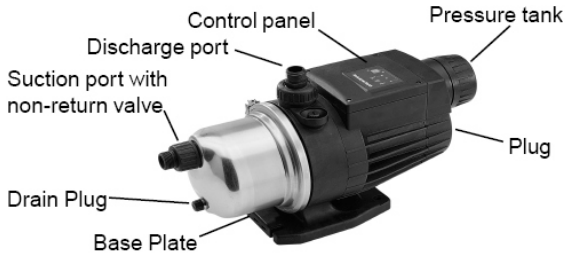

The MQ is a compact water supply system consisting of a pump, motor, pressure tank and controller combined in an integral unit.

- Starts automatically when water is consumed.
- Stops automatically when water consumption ceases.
- Can be installed both indoors & outdoors.
- Self priming & has a non-return valve in the suction port.
- Features a user-friendly control panel.
- Incorporated pressure tank reduces number of starts & stops.
- Includes over-temperature and dry-running protection.

APPLICATIONS

- Water boosting in storage tanks
- Water supply from wells

FEATURES & DIMENSIONS

- User-Friendly control panel
- Built-in pressure tank
- Low noise operation
- Flexible discharge connection

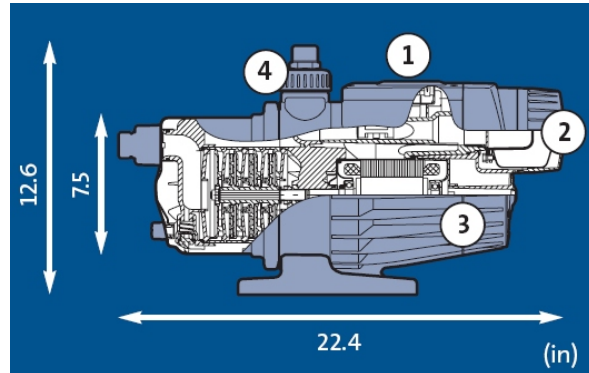

PERFORMANCE & SPECIFICATIONS

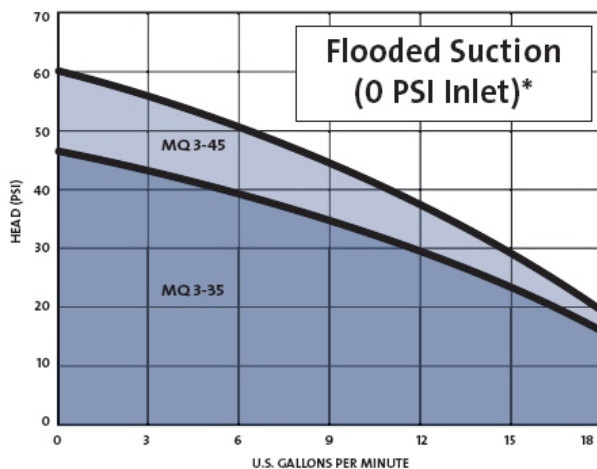

Performance range:	Flow up to 20 gpm Head up to 139 ft.
System pressure:	Up to 109 psi
Inlet pressure:	Max. 45 psi
Suction lift:	Max. 26 ft.
Liquid temperature:	32°F to +95°F
Ambient temperature:	32°F to +113°F
Nominal voltage range:	1Ø x 110 - 120 V 1Ø x 220 - 240 V
Weight:	29 pounds
Dimensions:	12.6 x 22.4 x 8.7 (in.)
Thermal protection	Yes